

# OVAL 3 STONES EcoDesign

# PANADERO



## MAßE

MAßE H x B x T	1048x605x490mm
GEWICHT BRUTTO/NETTO	197/187 kg
MAßE FEUERRAUMTÜR	355x440 mm
DURCHMESSER DES ABGASSTUTZEN	Ø 150-153 mm Vertikal
EXTERNE LUFTZUFUHR	Ø 80 mm

## EIGENSCHAFTEN

ROST AUS GUSSEISEN	
NENNLEISTUNG	8,7 KW
WIRKUNGSGRAD	80,7 %
CO - EMISSIONEN	0,10 %
HITZESCHUTZANSTRICH	800°C
GLASKERAMIKSCHEIBE HITZEBESTÄNDIG BIS	750°C

EAN 8426964183153

REF. PANADERO 18315

## PRODUKT PLUS

### ECODESIGN



EXTERNE  
LUFTZUFUHR



VERMICULIT AUSKLEIDUNG



DOPPELBLECHGEHÄUSE  
4 + 2,5 mm



HOLZFACH



SCHEITLÄNGE 50 CM



270  
m<sup>3</sup> RAUMHEIZVERMÖGEN



SCHEIBENSPÜLUNG



DREIFACHVERBRENNUNG



NATURSTEIN

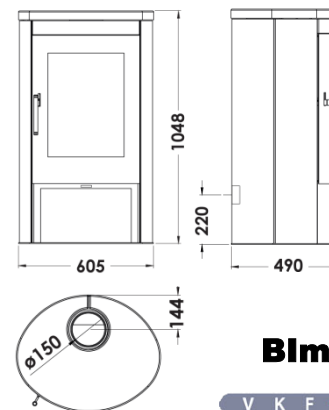

Art.15a B-VG



**BlmSchV2**



flamme  
VERTE

Le label  
du chauffage  
au bois

7 ★



OVAL 3S DE